

Freesmaten in bladen:

- Ingelegd                      rvs/blank      343,8X135X1,5 met +tol 0,2  
    poedercoating    344,1X135,3X1,7 met +tol 0,2
- Tafelblad doorvoer/oplegrand    334X123XR8

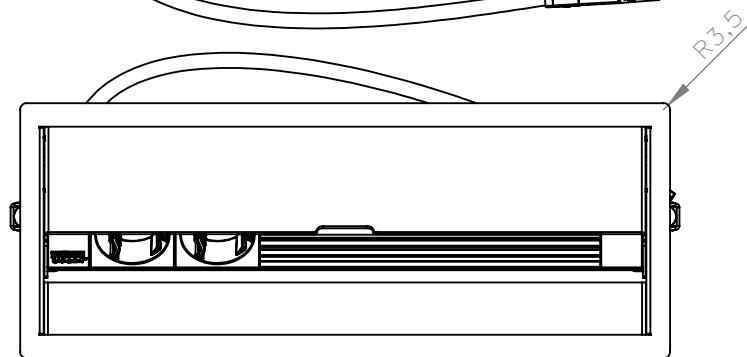
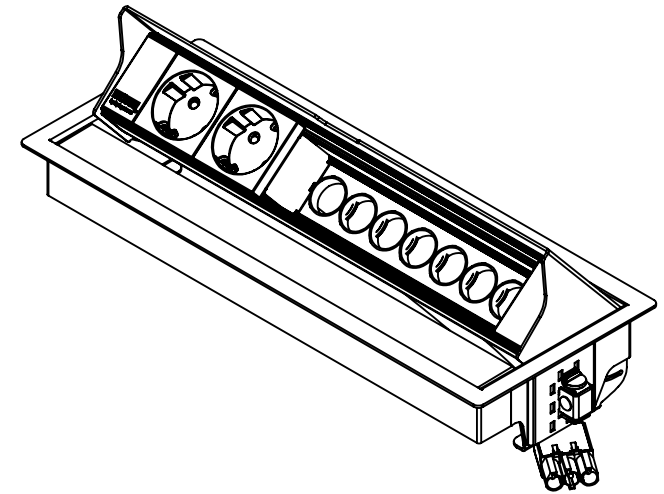
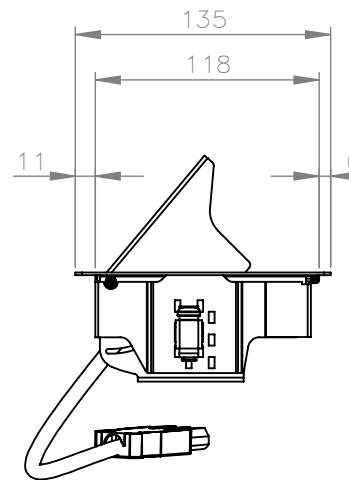
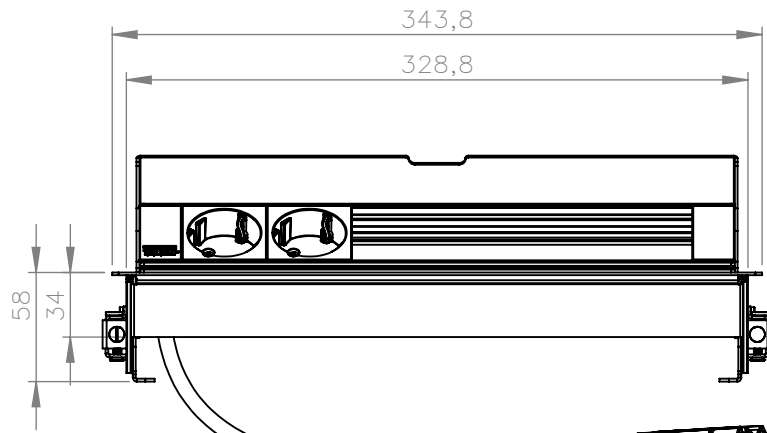

Alle maten in millimeters Alg. maat tol.                      ± 0,25 Alg. hoek tol.                        ± 0,25° Gereedschap                         0.6R 0.6			Tekening nummer <h1 style="margin: 0;">453.0034</h1>		Omschrijving, project Bureau-unit inbouw 6v "Joule"	
			Projectinformatie Indesq by HPL systems		Opmerking 2 wcd, 4 M45, kabelaanluiting 3-polig	
Getek.	Datum	Revisie	DO NOT SCALE DRAWING			
BR	3-3-2015	22-4-2016	Materiaal, nabehandeling			
			Material <not specified>			
			Gewicht in gram: 1560.2		Schaal: 1:4	
					Pagina 1 van 2	

Geschikt voor tafelbladen tot 30mm

**HPL HURKMANS PLATWERK BV**

Ontwerp en copyright Hurkmans Plaatwerk BV  
 niets uit deze tekening mag zonder schriftelijke toestemming  
 worden vermenigvuldigd of gebruikt door derden

A4

22-4-2016